

# TECHNICAL DATASHEET



## REDUCER

03 Update - 07/2024

### TECHNICAL DATA

Article No	001 117 0080 0453
d1 (mm)	450
d2 (mm)	315
Z (mm)	457
le1 (mm)	205
le2 (mm)	158
s1 (mm)	40,9
s2 (mm)	28,6
Weight (Kg)	18,520
Box Quantity (pcs)	8
Box Dimension (pcs)	80x120x100

### INJECTION MOULDED

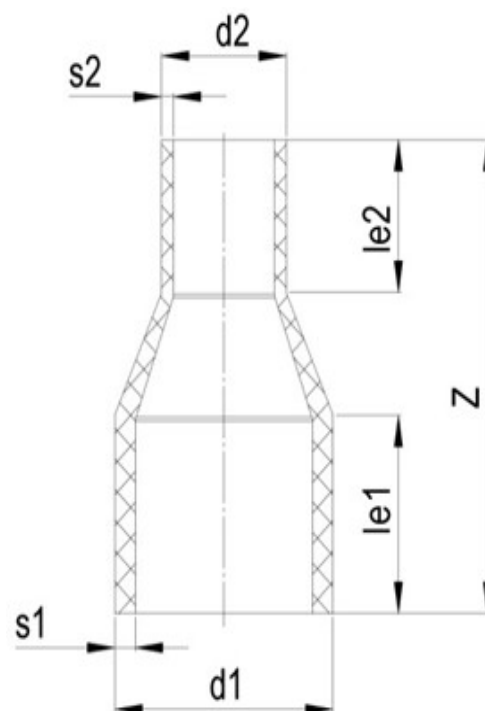

### IDENTIFICATION OF PRODUCT

D(mm)	450-315
SDR	11
RAW METARIAL	PE 100
PRESSURE CLASS	16 Bar Water 10 Bar Gas
TRADEMARK	NTG
EXECUTION	Injection Moulded
STANDARD	EN 12201-3 EN 1555-3 AS /NZS 4129

### SPECIFICATION

Long Spigot

Tolerance on diameters and thickness according to the standards. The other dimensions are specialized. Tolerance  $\pm 5\%$ . NTG PLASTIK reserves all the right to change any information without giving prior notice. The production, distribution and utilization of this document without explicit authorization is prohibited.